



VM1 Technical Manual

V1.7 -07-03-2025

OVERVIEW

Our aim is to empower you with the knowledge to confidently install and operate the VM1 Electric Brake Controller in any application. This guide is designed for professional installers and technically inclined vehicle owners, assuming a basic understanding of vehicle electrical systems. Following the provided instructions and safety precautions ensures the reliable performance and longevity of the VM1 brake controller. Let's get started!

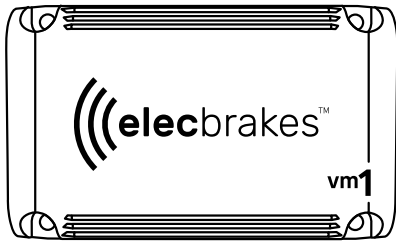

1. About The VM1	p.1
2. What's Included.....	p.2
3. Quick Start Options.....	p.2
4. Dimensions	p.2
5. Installation	p.3
6. Pairing The Unit	p.4
7. Confirm Operation.....	p.4
8. Adjusting Your Settings	p.5
9. Using The Override.....	p.6
10. Forward Direction Detect	p.6
11. Notifications And Warnings	p.7
12. Specifications & Ratings	p.8
13. Warranty Information.....	p.9
14. Compliance Information	p.9
15. 7-Pin Diagram.....	p.10
16. 12- Pin Diagram	p.11

1. ABOUT THE VM1

The VM1 is a vehicle-mounted electric brake controller designed for 12V and 24V systems, featuring an onboard accelerometer to detect deceleration and adjust braking force proportionally.

The VM1 allows for precise tuning of the braking response through four independent parameters, enabling customisation for different trailers, varying loads and road conditions. Five user defined programs facilitate quick adjustments to meet changing conditions. The override allows manual activation of trailer brakes independent of the tow vehicle, providing control during instances of sway or instability. Sleep mode conserves vehicle battery life, reducing its current draw to less than 10mA when not in use.

The device integrates seamlessly with CarPlay and Android Auto, enabling in-vehicle adjustments of brake settings, preset switching, and override function activation via the vehicle's head unit. The user can alternatively control the VM1 using the Elecbrakes app on their smartphone (iOS and Android supported) or with the EB remote.

The VM1 can be mounted to the tow vehicle externally, fastened on a rigid body point or installed internally, inside vehicle paneling according to user preference. The provided wiring harness is then routed to the vehicle's trailer plug for easy connection with the vehicle's existing circuits making for a quick and easy install.

VEHICLE REQUIREMENTS

⚡ +12V (25A) DC voltage source OR

⚡ +24V (12A) DC voltage source

⚡ DC negative (earth) point

Ⓞ Brake light voltage (12-24V DC)

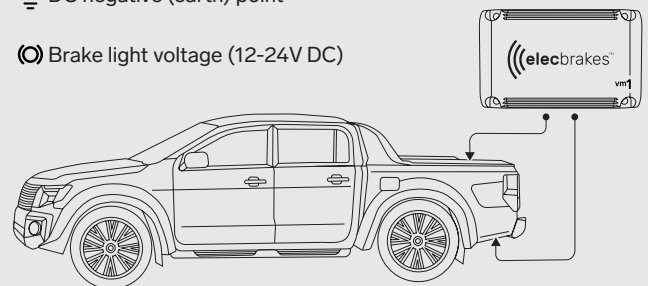

2. WHAT'S INCLUDED

1 VM1 Brake Controller



2 4x Self Tapping Screws



3 1.5m Leader

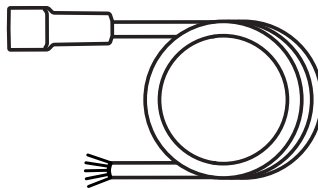

4 Quick Start Guide



3. QUICK START OPTIONS

There are 3 options for getting started with our quick start guide:



In-App Onboarding

Download the Elecbrakes app and follow the prompts to get started.



Quick Start Guide In The Box

Find a copy of our VM1 Quick Start guide inside the box.



The Quick-Install Video

Watch our VM1 Quick Install Guide video.

4. DIMENSIONS

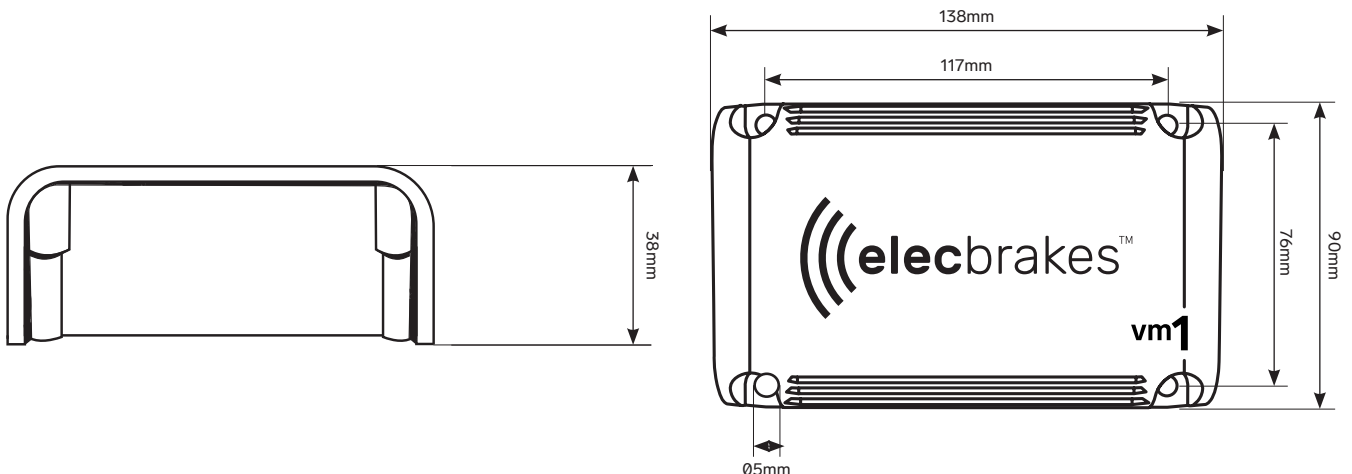

5. INSTALLATION

Choose a suitable location for mounting the VM1; such as the luggage compartment, rear quarter panel, ute tray or vehicle under body. Ensure the brake controller is mounted securely, within reach of the wiring harness and is out of harms way. Fasten the VM1 to the car body using the 4x self tapping screws supplied.



For correct forward direction detection and accurate proportional control you **MUST** ensure one of the unit's sides or faces is approximately parallel to the ground. This can be done by eye and does not require a spirit level or specialist tools.

You may require pilot holes prior to fastening, we recommend a 4mm drill bit or alternatively lubrication to aid in fastening. Ensure the VM1 is securely fastened before proceeding.

Mounting Orientations:

VM1 Unit must be mounted with one face parallel to the ground.

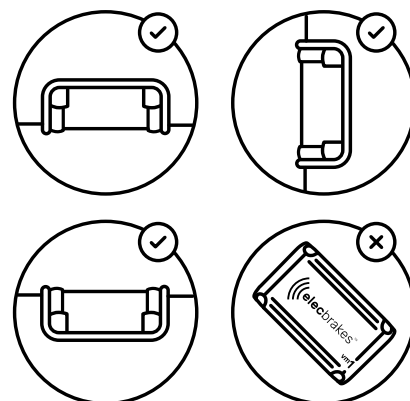

Wire in the exposed end of the leader into the vehicle's existing trailer socket using the CONNECTIONS / WIRING guide to the right. You can also view a full wiring diagram for both 7-pin and 12-pin socket types at the end of this document.

1. Unscrew the top / bottom covers of your vehicle's trailer socket to expose the wiring.
2. Match the colours of the wired leader (supplied) to the requisite positions on the trailer plug.
3. Use the pin-outs below to aid in the wiring process. You can also find full wiring diagrams for 7-pin and 12-pin installations at the end of this document.
4. Fasten the covers back onto the vehicles socket.



We recommend a 25A rated circuit be installed for pin 2 on a 7-pin socket. For 12 pin sockets, pin 8 or pin 9 is suitable.

It's good practice to check each of the relevant circuits for an output of at least 10Vrms.

Some vehicles use pin 5 as an ignition power feed. In these cases disconnect pin 5 from the output for correct operation.

7-PIN

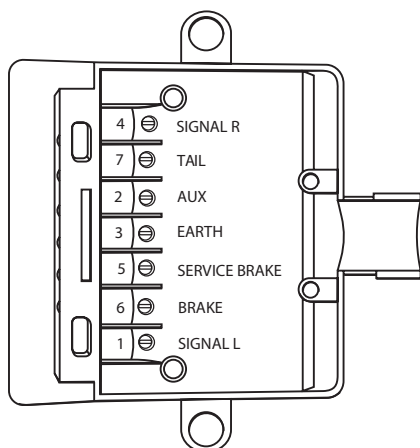

12-PIN

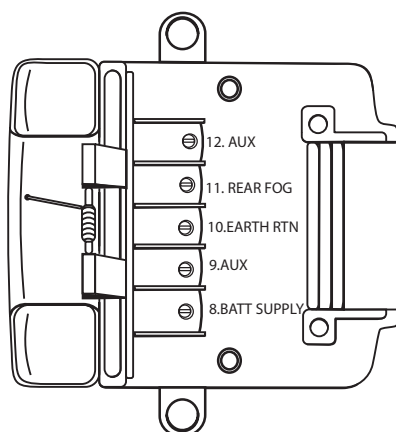

CONNECTIONS / WIRING GUIDE

BLACK DC Voltage Supply

RED Brake Light Voltage Supply

BROWN Not Used

WHITE DC Negative Earth

BLUE Service Brake Output

6. PAIRING THE UNIT

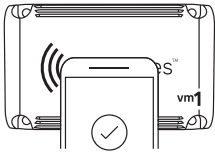

Tap

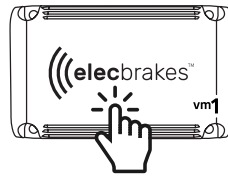

Select Your Device



Follow the prompts

Open The App

Upon opening, the app will ask you to select your device type and guide you through a short onboarding process, which includes;

- Installation
- Pairing to the VM1
- Adjusting the brake responses

From here you can choose to view the entire process, or jump in to the section of your choosing.

Pairing The Unit

Pairing the unit consists of the following steps:

- Turn the vehicle on (in case of a switched auxiliary feed)
- Search and connect via the app
- Brake signal check to confirm wiring

Alternatively, should you choose to skip onboarding, a device can be paired through the 'ADD DEVICE' button on the 'Devices' page.

Download The App



You must use the Elecbrakes app on your smartphone for the initial connection and setup of your brake controller.

Minimum requirements

- iOS 15 or later
- Android 10 or later

7. CONFIRM OPERATION



Confirm a correct installation by observing the tick icon change to a braking icon when placing your foot on the brakes.



Observe power delivery to the brakes by looking at the Output section on the data page of the app. Place your foot on the brake and confirm voltage and current are non-zero.

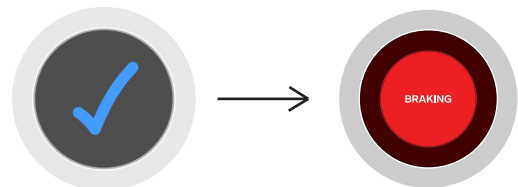

OUTPUT

Voltage	4.00 V
Current	1.00A

8. ADJUSTING YOUR SETTINGS

The VM1 is a proportional brake controller. This means it applies a varying brake force on the trailer in direct proportion to how hard you, the driver, are braking. So how do Elecbrakes brake controllers deliver such a smooth braking experience allowing you to 'set and forget' your preference for seamless operation? In addition to our own proprietary braking algorithms, we achieve this by giving you full customisation of your setup, allowing for independent control of the brake controllers' minimum, forward & reverse settings in addition to the override value - not to mention multiple preset programs for varying setups and conditions. But what do all these settings do? Let's dive in...

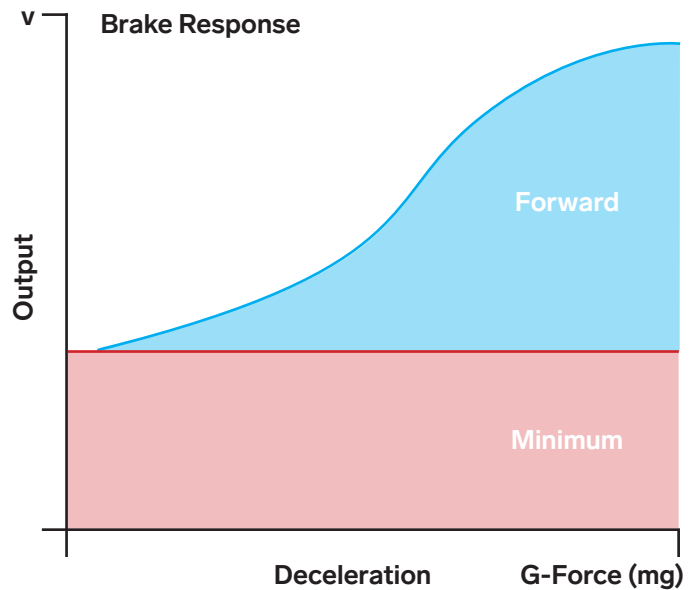

Minimum Response

You may have noticed while driving that when placing your foot on the brake you can activate your brake lights without applying pressure to the brakes. In this condition, the brake controller detects the brake light turn on, but there is no deceleration from braking. Elecbrakes brake controllers have the ability to apply a user defined brake output in this case, referred to as a 'Minimum'. Think of it like an offset or bias. Having independent control of the minimum allows you to tune in your brake response according to your preference, taking into account your setup, loading conditions, road conditions and more. A well setup minimum is crucial in achieving a smooth and comfortable brake response so be sure to experiment. **A good place to start is 10%, adjusting up or down according to preference.**

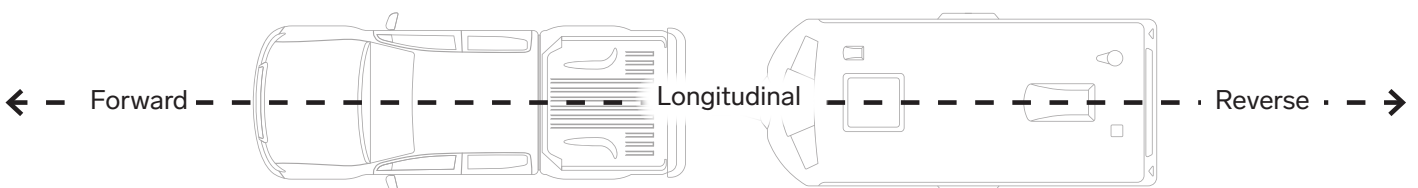

Forward Response

The Forward response represents the proportional component of your brake controller's output in the forward longitudinal direction. You can think of this as being system gain or sensitivity to deceleration. This Forward response will be added on top of your Minimum response giving you the overall braking response of the system. **A good place to start is 40%, adjusting up or down according to preference.**

Reverse Response

The Reverse response represents the proportional component of your brake controller's output in the reverse longitudinal direction. We find because you reverse at much slower speeds than normal driving it is beneficial to have an independent reverse response setting. **A good place to start is 10%, adjusting up or down according to preference.**

9. USING THE OVERRIDE

In conditions of high wind or system instability, usually due to poor loading or heavy crosswinds, your trailer or caravan can begin to oscillate, rocking side to side with increasing amplitude. If this effect is not corrected, it can very quickly become a serious incident. This is where the override function comes into play, allowing you to manually engage the trailer brakes independently of the vehicle's brakes. This causes your vehicle to pull forward while your trailer pulls backward, helping to stabilise the system.

The override function delivers a constant voltage to the brakes, providing a steady braking force without control based on deceleration ie: there is no proportional component present when using the override. However, Elecbrakes brake controllers are designed to always apply the larger of the two braking values (Override vs Braking response), this means that in the case where you need to make an emergency stop while overriding, Elecbrakes brake controllers will prioritise the stronger braking force to ensure safety. **A good starting point is to set the override preset value equal to the forward response value and adjust from there, according to preference.**

Activating Override

- Tap the circle on the app's home screen to apply the preset override value.
- To increase the override force, hold down the circle to progressively raise the braking force. Release to stop at the desired value.
- Tap again to disable the override.

If you are using an Elecbrakes remote, the override is triggered by a force sensitive button. Apply more force to apply a larger override value.

NOTE: The remote override button does not latch.

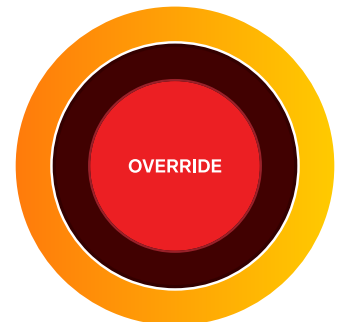
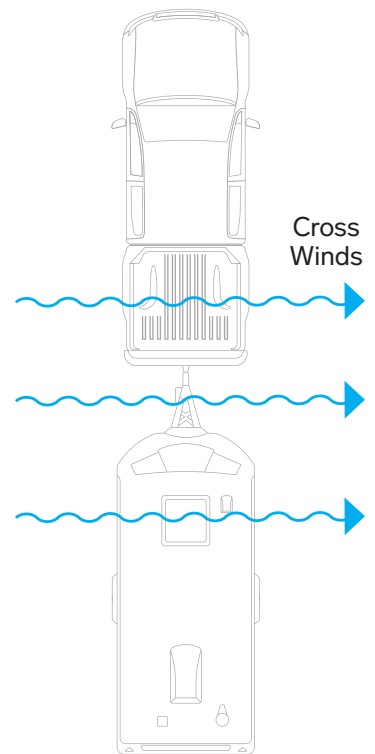

10. FORWARD DIRECTION DETECT

Elecbrakes brake controllers use a proprietary algorithm to determine the forward longitudinal direction of your vehicle. This allows precise proportional control with unparalleled accuracy and confidence. The VM1 will automatically calibrate, refining this measurement on an ongoing basis and is not something you need to set or worry about! This system will, however require a couple of brake applications to set this angle initially.

NOTE: Prior to setting a forward direction, the VM1 will use a default 4V output for all brake applications. Whilst this will likely feel aggressive, it will ensure a rapid detection of the forward direction within only a few applications.



If you happen to move the install location or orientation of the VM1 remember to power cycle the unit before proceeding. This is as simple as disconnecting and reconnecting the wired leader deutsch plug. Remember, your device will take a couple of brake applications to re-calibrate the forward direction.

11. NOTIFICATIONS & WARNINGS



Elecbreaks brake controllers offer advanced features designed to keep you informed and safe at all time. The VM1 can instantly notify you through the app if there's a problem with your setup or something isn't looking quite right. This includes short circuit detection, low system voltage warnings and more.

Additionally, you'll receive key updates and new feature developments directly to your phone, keeping you safe, informed, and in control, providing peace of mind while towing. Remember, for access to the latest notifications & warnings, you must use the App, Apple CarPlay, or Android Auto.

Warnings

The VM1 brake controller will actively protect against a range of system faults, notifying you of exactly what is happening and directing you towards potential issues and fixes for your setup. This is in addition to the real-time information available to you via the data page of the app.



WARNING
VM1 - Low System Voltage
System Voltage Low - Check Connections



WARNING
VM1 - Excessive Current Detected
Check Braking System



WARNING
VM1 - Short Circuit Detected
Output Disabled - Check Wiring Before Proceeding



WARNING
VM1 - Temperature Warning
Regulated Output

Updates

Elecbreaks brake controllers are continually getting better, whether it's new features, performance improvements or requests from our user base, one thing's for certain - your brake controller will get even better over time. Every VM1 has the ability to download the latest software via the app, ensuring you're brake controller will never get left behind.

Elecbreaks will even notify you if there's a product specific upgrade available for your VM1.

No spam, no ads - just upgrades.



VM1 Update Available
We've been working hard to make your VM1 even better! Connect to your VM1 and check for updates on the settings page.



Product Upgrade Available
Upgrade your brake controller to actively mitigate and control for trailer instability. Tap here to learn more.

12. SPECIFICATIONS AND RATINGS

		Input		
Electrical Characteristics	Input voltage (nominal)	12V & 24V systems		
	Power input	Auxiliary circuit		
	Signal input	Brake light circuit		
	Max input voltage	28Vdc		
	Startup voltage	6Vdc		
	Operating voltage	>10Vdc		
	Operating current	≈40mA		
	Standby current	<10mA		
			Output	
	Max output voltage	12Vrms		
Continuous output current	24A			
Peak output current	32A			
Short circuit protection timing	32μS			
Output signal characteristics	457 Hz PWM			

Mechanical Characteristics	IP rating	IP67	
	Dimensions (W x L)	90mm x 138mm	
	Housing material	Glass reinforced nylon	
	Fasteners	S500 self tapping ph3 head	
	Encapsulant	Polyurethane elastomer	

Thermal Properties	Operating range	-30C to 75C ambient	
	Over temperature output throttling	145C internal	

Other	Bluetooth version	5.2	
--------------	-------------------	-----	--

13. WARRANTY INFORMATION

The following applies to Elecbrakes products purchased in Australia: Our goods come with guarantees that cannot be excluded under the Australian Consumer Law. You are entitled to a replacement or refund for a major failure and compensation for any other reasonably foreseeable loss or damage. You are also entitled to have the goods repaired or replaced if the goods fail to be of acceptable quality and the failure does not amount to a major failure.

The following applies to Elecbrakes products purchased in New Zealand: If the Consumer Guarantees Act 1993 ('CGA') applies, our goods come with guarantees that cannot be excluded except in accordance with the CGA. Where goods fail to comply with a guarantee, you are entitled to a repair, replacement or refund and compensation for reasonably foreseeable loss or damage. You are also entitled to compensation for a reduction in the value of goods where a failure is substantial or cannot be remedied.

In addition to your rights and remedies at law, all Elecbrakes products purchased in Australia and New Zealand are covered by the Elecbrakes Product Warranty. This Product Warranty is provided by:

Elecbrakes Pty Ltd
878 Pacific Highway
Lisarow NSW 2259
Tel: 1300 516 248
Email: warranty@elecbrakes.com



For Elecbrakes **Warranty Terms** and Conditions, please visit our website or scan the QR code.

14. COMPLIANCE INFORMATION

Elecbrakes VM1 holds the following product compliances:



RCM - Electrical Equipment Safety Scheme



IP67 - Ingress Protection to IEC 60529:1981+A1:1999+A2:2013+COR1:2019
- Submersible in water up to 1m deep for at least 30 minutes.



FCC - Contains Transmitter Module FCC ID: QOQ-BGM220S



CE - Compliant with EU health, safety, and environmental requirements

15. 7-pin Wiring diagram

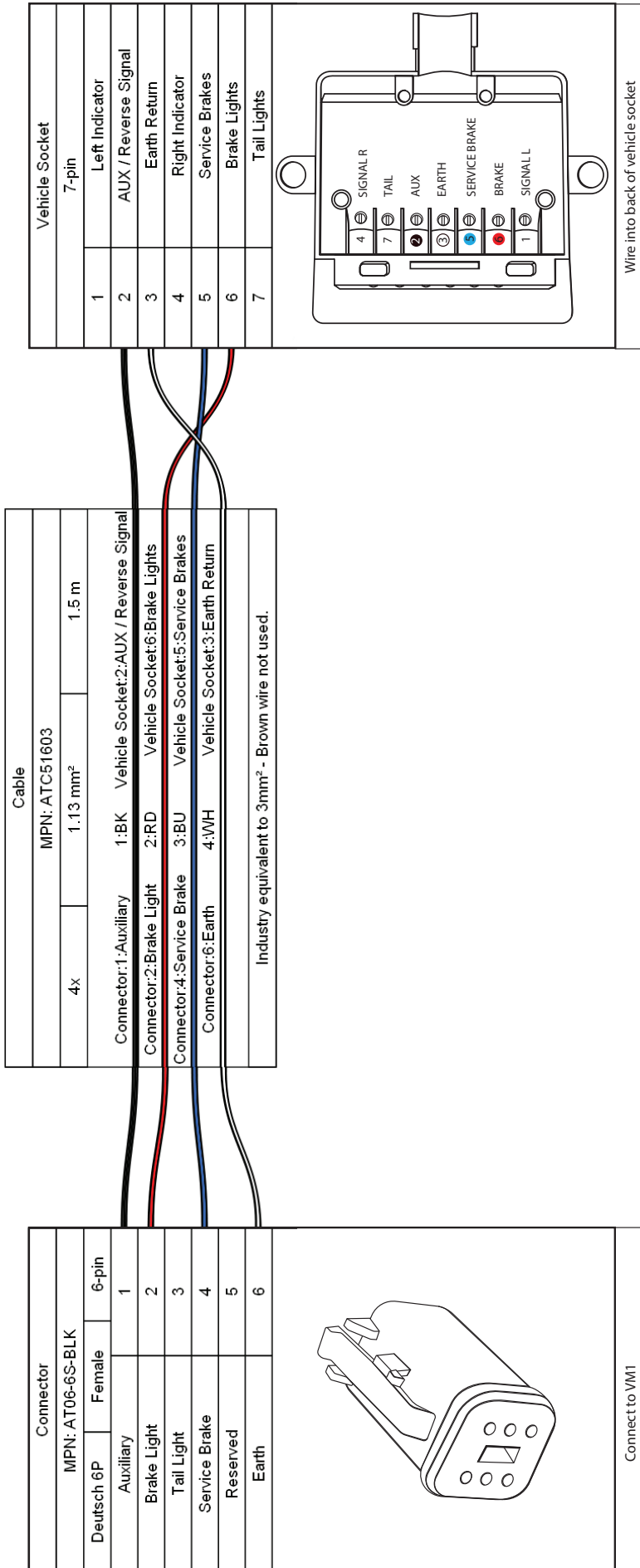

16. 12-pin wiring diagram

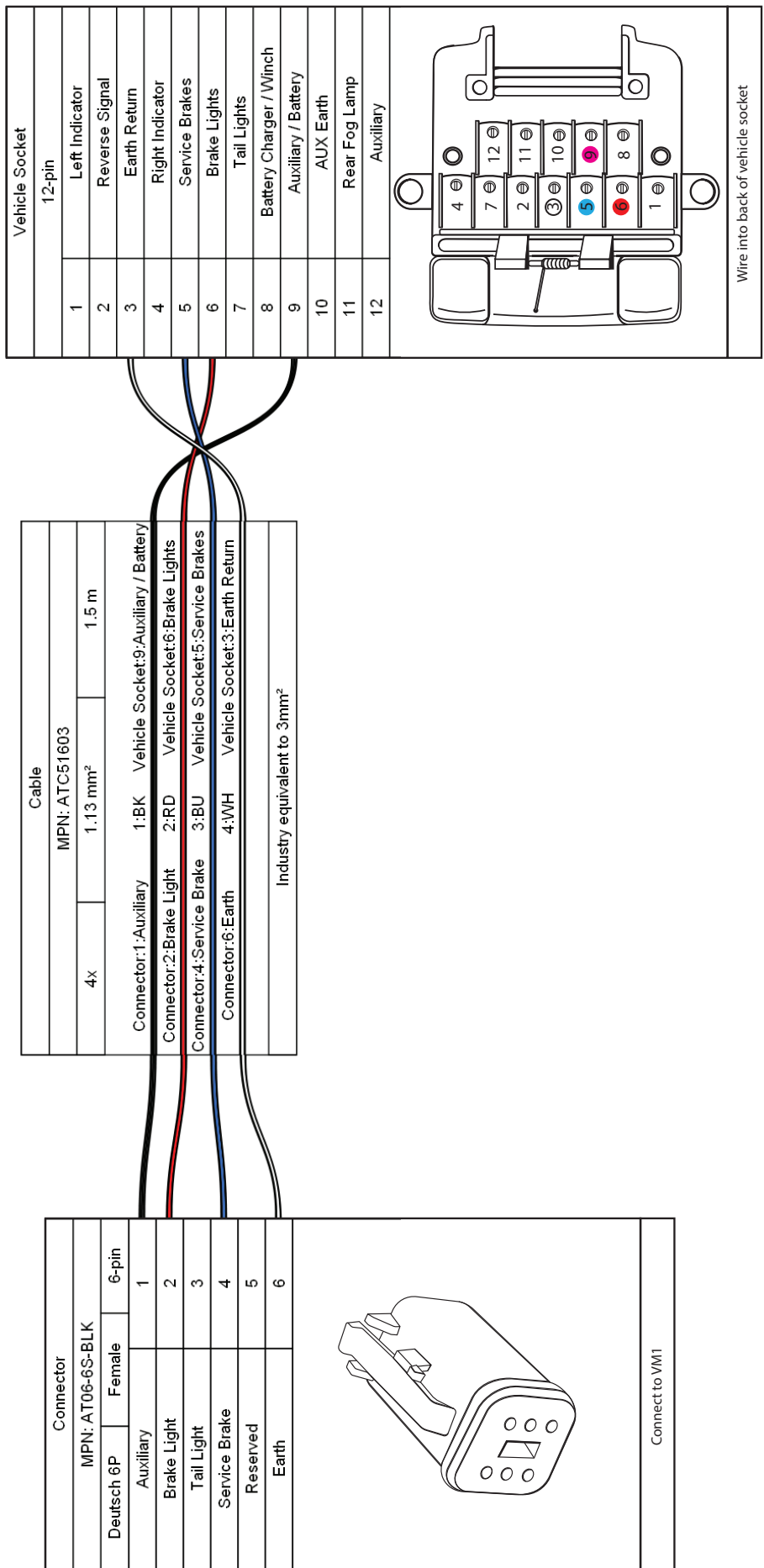



NEED HELP?

Check out our FAQ page online
elecbrakes.com/FAQ



or call our customer service team on
1300 516 248